

Okazaki Fragment Maturation in Yeast

I. DISTRIBUTION OF FUNCTIONS BETWEEN FEN1 AND DNA2*

Received for publication, September 24, 2002, and in revised form, October 30, 2002
Published, JBC Papers in Press, November 6, 2002, DOI 10.1074/jbc.M209801200

Rao Ayyagari‡§, Xavier V. Gomes‡¶, Dmitry A. Gordenin||, and Peter M. J. Burgers‡**

From the ‡Department of Biochemistry and Molecular Biophysics, Washington University School of Medicine, St. Louis, Missouri 63110, ||Laboratory of Molecular Genetics, NIEHS, National Institutes of Health, Research Triangle Park, North Carolina 27709, and §Lindenwood University, St. Charles, Missouri 63301

In the presence of proliferating cell nuclear antigen, yeast DNA polymerase δ (Pol δ) replicated DNA at a rate of 40–60 nt/s. When downstream double-stranded DNA was encountered, Pol δ paused, but most replication complexes proceeded to carry out strand-displacement synthesis at a rate of 1.5 nt/s. In the presence of the flap endonuclease FEN1 (Rad27), the complex carried out nick translation (1.7 nt/s). The Dna2 nuclease/helicase alone did not efficiently promote nick translation, nor did it affect nick translation with FEN1. Maturation in the presence of DNA ligase was studied with various downstream primers. Downstream DNA primers, RNA primers, and small 5'-flaps were efficiently matured by Pol δ and FEN1, and Dna2 did not stimulate maturation. However, maturation of long 5'-flaps to which replication protein A can bind required both DNA2 and FEN1. The maturation kinetics were optimal with a slight molar excess over DNA of Pol δ , FEN1, and proliferating cell nuclear antigen. A large molar excess of DNA ligase substantially enhanced the rate of maturation and shortened the nick-translation patch (nucleotides excised past the RNA/DNA junction before ligation) to 4–6 nt from 8–12 nt with equimolar ligase. These results suggest that FEN1, but not DNA ligase, is a stable component of the maturation complex.

In eukaryotic cells, Okazaki fragments are efficiently matured during elongation of DNA replication. Earlier models of this process, based on *in vitro* replication studies of simian virus 40 DNA, implicated the FEN1 5'-FLAP-exo/endonuclease and RNase H1 as the main degradative enzymes to remove the RNA moiety of the Okazaki fragment and provide an appropriate gap for filling by a DNA polymerase and sealing by DNA ligase I (for reviews, see Refs. 1 and 2). Recent studies of the mutator phenotypes of *RAD27* (encoding FEN1), *RNH35* (encoding RNase H1), and the double mutants suggest that the two enzymes function in separate pathways (3). Rather, genetic studies have suggested that an essential nuclease/helicase, Dna2, may be an important component of the lagging-strand replication apparatus based on several criteria, including synthetic lethality of temperature-sensitive mutations in *DNA2* with a deletion mutation of the *RAD27* gene (4, 5). *DNA2* shows

genetic interactions with DNA polymerase alpha and alpha-accessory proteins (6), and the temperature sensitivity of *S. pombe DNA2* mutants is suppressed by overexpression of each of several genes playing a role in the elongation and maturation of Okazaki fragments, including those encoding FEN1, DNA ligase, and DNA polymerase δ (Pol δ)¹ (7). Subsequent to the demonstration of a rather inefficient helicase activity in Dna2, a 5' \rightarrow 3'-endonuclease activity was characterized, and it is the nuclease rather than the helicase that confers the essential phenotype (8–10). In addition, *DNA2* is required for the proper maintenance of telomeres (11, 12).

Beyond its demonstrated function in Okazaki-fragment maturation, FEN1 plays an important role in several other DNA metabolic processes. In DNA repair, FEN1 is required for long-patch base-excision repair (13–15). Repetitive sequences are destabilized in *RAD27* deletion strains, and such strains are strong mutators (16–18). Genetic and biochemical studies indicate that FEN1 preferentially restricts recombination between short repeated sequences (19–21). Lesions that accumulate in the absence of FEN1 require homologous recombination for repair as *RAD27* deletion results in poor growth or lethality in recombination-defective backgrounds (22, 23). Some, but not all of the *rad27*- Δ phenotypic defects are suppressed by overexpression of the *EXO1* gene that encodes a related nuclease (11, 24). In addition, the temperature sensitivity of a *rad27*- Δ mutant is suppressed by overexpression of the *DNA2* gene (5). In many if not all of these processes, the activity of FEN1 depends on its interaction with the replication clamp PCNA (proliferating cell nuclear antigen), and synthetic lethality is observed between *RAD27* and *POL30* (encoding PCNA) mutants (25, 26).

FEN1 is a structure-specific nuclease that cleaves substrates containing unannealed 5'-flaps (reviewed in ref. 27). Biochemical and structural studies are consistent with a model in which FEN1 loads by sliding onto the 5'-unannealed strand of the flap. The crystal structure of archeobacterial FEN1 shows a long flexible loop near the active site, which forms a hole large enough to accommodate the DNA substrate (28, 29). Sliding occurs most efficiently across single-stranded DNA; double-stranded DNA flaps and protein-bound flaps poorly support loading of FEN1 (30). Cleavage removes the flap at or near the point of annealing. The favored substrate for the FEN1 class of nucleases is actually a double-flap structure containing a 1-nt 3'-tail on the upstream primer adjacent to the 5'-flap. With this double-flap substrate, the site of cleavage is one nucleotide into

* This work was supported by National Institutes of Health Grant GM58534. The costs of publication of this article were defrayed in part by the payment of page charges. This article must therefore be hereby marked "advertisement" in accordance with 18 U.S.C. Section 1734 solely to indicate this fact.

¶ Present Address: 454 Corporation, 20 Commercial St., Branford, CT 06405.

** To whom correspondence should be addressed. Tel.: 314-362-3872 Fax: 314-362-7183; E-mail: burgers@biochem.wustl.edu.

¹ The abbreviations used are: Pol δ , DNA polymerase δ ; RFC, replication factor C; RPA, replication protein A; PCNA, proliferating cell nuclear antigen; ss, single-stranded; nt, nucleotide; SSB, single-stranded DNA-binding protein.

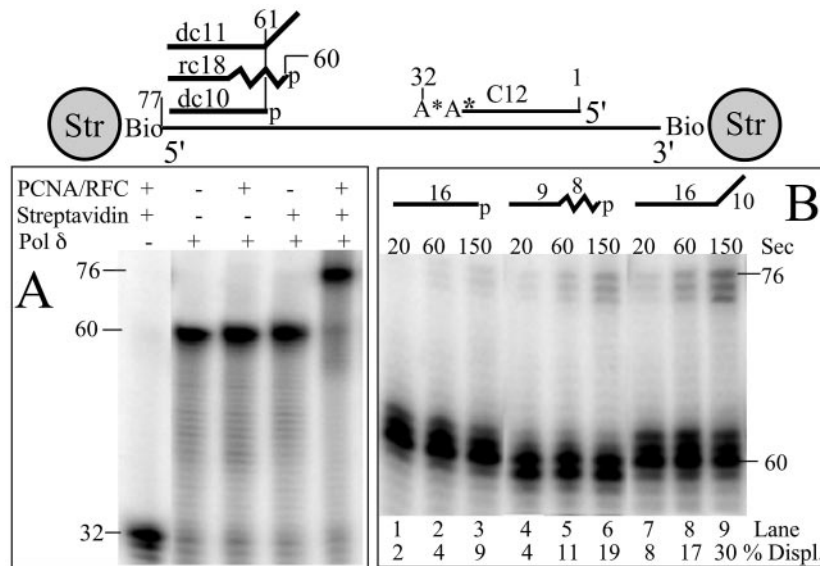

FIG. 1. PCNA-dependent strand displacement synthesis by Pol δ . Replication reactions contained 100 fmol of a 107-nt 3'- and 5'-biotinylated template with a 3'-end labeled primer C12 and either second primer dc10 (A and B, lanes 1–3), or rc18 (lanes 4–6), or dc11 (lanes 7–9). A, standard replication reactions contained 125 mM NaCl, RPA, Pol δ , and RFC and PCNA where indicated for 10 min at 30 °C. Streptavidin was added to the biotinylated template where indicated. B, standard replication assays on the three different streptavidin-biotin template/primer substrates as indicated above the figure contained 125 mM NaCl. The reactions were preincubated with RPA, PCNA, and RFC for 1 min at 22 °C, and then started by addition of Pol δ . Further incubation was at 22 °C for the indicated times. The products were separated on a 7 M urea/12% polyacrylamide gel. The length of extension products with relation to the downstream primer is indicated. Precise gap filling by Pol δ produces a 60-mer with oligonucleotides dc10 and dc11, and a 59-mer with oligonucleotide rc18. See “Experimental Procedures” for details.

a single nucleotide by the polymerase (Fig. 1B). The nature of the pause site and factors driving departure from the pause are discussed in the accompanying paper (52).

As expected from our knowledge of the preferred substrate for cleavage by FEN1, the primers hybridized to the biotinylated template in this assay system formed poor substrates for degradation by FEN1, even with PCNA present (data not shown). However, when both Pol δ and FEN1 were added to this DNA substrate onto which PCNA had been loaded by RFC, both enzymes acted synergistically to effect rapid nick translation (Fig. 2). For FEN1 to act effectively during nick translation, interaction with PCNA is required. FEN1 interacts with PCNA through a consensus PCNA-binding motif QGRLDGFF (42, 53, 54). A mutant form of FEN1, fen1-ga (FF346,347GA), retains full nucleolytic activity but shows a greatly reduced interaction with PCNA (42). Here, its capacity to enhance DNA synthesis by Pol δ through the downstream primer was also greatly impaired (Fig. 2).

We used a circular ssDNA replication system to dissect the individual steps of the maturation process. Single-stranded Bluescript DNA was primed with a 1.14-kb 3'-end labeled primer and replicated with Pol δ holoenzyme (Pol δ , PCNA, and RFC) in the presence of RPA (Fig. 3A). Elongation proceeded continuously until the 5'-end was reached after 30–45 s for most complexes, corresponding to a rate of 40–60 nt/s. This rate is consistent with the average rate of fork migration of 50 nt/sec measured recently in a whole-genome analysis (55). Strand-displacement synthesis by Pol δ holoenzyme proceeded for a subset of the complexes; 30–40% did not initiate strand-displacement synthesis during the time course of the assay (Fig. 3B). Those complexes that did carry out strand-displacement synthesis produced a broad band of extension products, which was detected using denaturing agarose electrophoresis. The median of this band corresponded to an average rate of $\sim 1.5 \pm 0.5$ nt/sec for strand-displacement synthesis by Pol δ holoenzyme. However, the fastest 10% of complexes proceeded at a rate of 3–4 nt/s.

The same substrate also allowed us to measure rates of nick

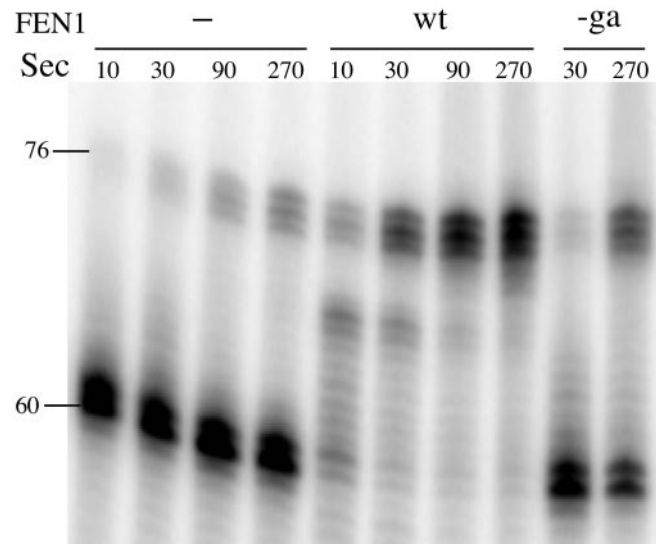
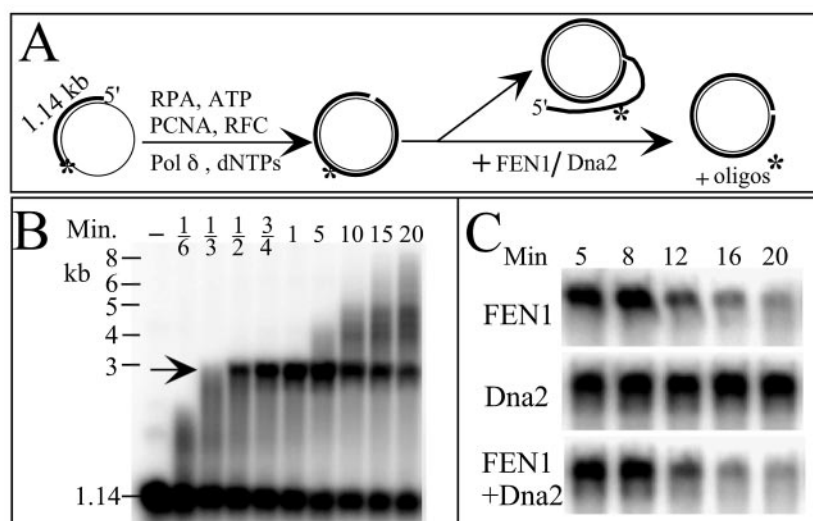

FIG. 2. Interaction between FEN1 and PCNA required for nick translation. Replication reactions were as described in Fig. 1B, with oligonucleotide dc10 as the downstream primer, and also contained when present 150 fmol of either wild-type (*wt*) FEN1 or fen1-ga (*-ga*). The reactions were preincubated with RPA, PCNA, and RFC for 1 min at 22 °C, and then started by adding the other proteins in a mix. Aliquots were taken after the indicated times at 22 °C and analyzed on a 7 M urea/12% polyacrylamide gel. The major pause site (60-mer) is at the precise position of the nick.

translation. Because the 1.14-kb long primer is labeled at the 3'-position, it follows that this label will be lost from the DNA after nick translation has proceeded for that distance (Fig. 3, A and C). The time point at which half of the label has been lost is used to calculate the average rate of nick translation. This time was corrected for the period (~ 45 s) required to completely replicate the ssDNA circle. With FEN1 present, half of the label was lost after 11 min of incubation, corresponding to an average nick-translation rate of $\sim 1.7 \pm 0.5$ nt/sec, comparable with

FIG. 3. **Strand-displacement synthesis and nick translation by Pol δ and FEN1.** *A*, schematic of the assays. *B*, strand-displacement synthesis. Alkaline agarose electrophoretic analysis of strand displacement synthesis. Standard assays contained 100 mM NaCl, RPA, RFC, PCNA, and Pol δ for the indicated times at 30 °C (see "Experimental Procedures" for details). The reactions were preincubated with RPA, PCNA, and RFC for 1 min at 30 °C, and then started by adding Pol δ . The arrow indicates fully replicated Bluescript SKII DNA (2.9 kb). The label remaining at 1.14 kb is material that did not hybridize to the ss SKII DNA. *C*, nick translation. Alkaline agarose electrophoretic analysis of replication reactions as described under *B*, but with in addition either FEN1, Dna2, or both added together with Pol δ . Only the region around 2.9 kb is shown.



the rate of strand displacement synthesis by Pol δ holoenzyme in the absence of FEN1 (Fig. 3C). About 20% of the label remained even after 20 min of incubation and probably represents disassembled complexes. The Dna2 nuclease poorly supported nick translation, whereas its inclusion together with FEN1 did not alter the rate of nick translation obtained with FEN1 alone. Nick translation over extended stretches of DNA as carried out in this experiment allowed us to determine an elongation rate for this process, but this assay does not reflect a physiological maturation assay in which nick translation may proceed for only a few nucleotides (see below). Therefore, in addition to obtaining a rate of nick translation, it may be equally important to determine the factors and conditions that initiate this process.

Gap Filling by Pol δ Produces Ligatable Nicks—To assess with what efficiency and precision Pol δ holoenzyme fills gaps generated during DNA metabolic processes, *e.g.* nucleotide-excision repair, we carried out replication assays on primed circular Bluescript SKII ssDNA in the presence of DNA ligase. Covalent closure of the replicated strand by DNA ligase was detected by electrophoresis through an agarose gel in the presence of ethidium bromide, which causes an abnormally rapid migration of covalently closed circular DNA. With a 5'-phosphorylated fully hybridized primer, replication by Pol δ holoenzyme proceeded with remarkable precision to form a ligatable nick. In the presence of DNA ligase, predominantly (87%) covalently closed DNA circles were produced (Fig. 4B, lane 1). Formation of ligated DNA required that the primer contain a 5'-phosphate and the presence of DNA ligase (data not shown), and proceeded with virtually 100% efficiency when FEN1, but not Dna2 was included in the assay (lanes 2 and 3).

Efficient Okazaki Fragment Maturation by Pol δ and FEN1—A primer with 8 nt of RNA followed by 22 nt of DNA was used as a model substrate for Okazaki-fragment maturation. Although the primer contained a 5'-phosphate, no ligated products were detected when the DNA was replicated with Pol δ holoenzyme in the presence of DNA ligase (Fig. 4, lane 6). Even a 10-fold excess of DNA ligase in this assay failed to produce a detectable ligation product (data not shown). Although this substrate specificity is one that might logically be expected for a DNA ligase involved in Okazaki-fragment maturation, surprisingly, previous biochemical studies of DNA ligase have shown rather efficient ligation of (rA)-oligomer hybridized to poly(dT) (56). Ligation of essentially all replicated molecules was observed when FEN1 was included in the assay, whereas Dna2 functioned poorly (lanes 7 and 8).

Maturation of Long Flaps Requires DNA2—We used two primers in our maturation studies, which contained 5'-flap; one flap was 10 nt long and the other flap was 30 nt in length. The formation of ligated products with the 10-nt flap was similar to observed with the RNA-DNA primer, *i.e.* FEN1 was fully effective and the efficiency of Dna2 was much lower, requiring a 10-min incubation at 30 °C to catalyze the accumulation of 82% ligated circles (Fig. 4C, lanes 1–6). On the other hand, replication of the primer with the 30-nt flap showed dramatically different results. Only 27% of the replication products had ligated after a 10-min replication reaction in the presence of FEN1 as processing nuclease. Dna2 was more effective with 88% ligation products after 10 min of reaction (lanes 7–12). However, the presence of both FEN1 and DNA2 was essential to achieve both rapid and complete ligation (lanes 13–15). Our results with the 30-mer flap are in agreement with recent studies of Okazaki-fragment maturation that indicate that binding of RPA to long flap prevents the action of FEN1 (34). Degradation of the long flap by Dna2 would produce shorter flaps, as exemplified in our 10-mer flap substrate, which could then be efficiently degraded by FEN1.

When *E. coli* SSB was used as ssDNA-binding protein, maturation of DNA with the 30-mer flap primer was also very inefficient, similar to observed with RPA (Fig. 5A, lane 2). However, although addition of Dna2 rescued the maturation reaction with RPA present, Dna2 did not rescue when the DNA was coated with SSB (compare lanes 6 and 8 with lanes 2 and 4). Dna2 shows specific protein-protein interactions with RPA, which may serve to load Dna2 at the RPA-bound flap (34). When we substituted RPA with the large subunit of RPA, designated Rpa1, in the maturation assay, Dna2 similarly rescued maturation of the substrate with the 30-mer flap, suggesting that the important biochemical interactions of Dna2 are with the large subunit of RPA (lanes 10 and 12). As a control, maturation of the substrate with the 10-mer flap was fully efficient under all conditions.

Kinetic Analysis of Okazaki-fragment Maturation—Using our model RNA-DNA primed circular DNA, we determined the maturation time, *i.e.* the time required to convert nicked DNA circles into covalently closed DNA. An example of this analysis is given in Fig. 6B. The level of nicked circles peaked at ~40% after 60 s, then decayed to zero with the formation of covalently closed circles (Fig. 6, C and D). In our analysis, the maturation time is defined as the difference in the time required to replicate 50% of the DNA (nicked and covalently closed circles) and the time required to convert 50% of the nicked DNA to covalent

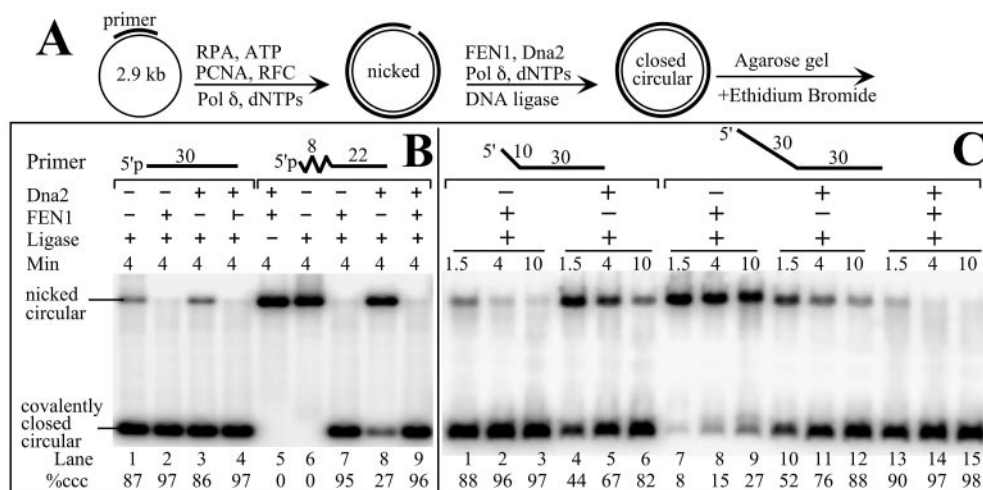

FIG. 4. Coupling DNA replication to maturation. *A*, schematic of the assays. *B*, maturation of a double-stranded DNA (SKdc10) or RNA-DNA primer (SKrc14), both containing a 5'-phosphate. Standard assays contained 100 mM NaCl, RPA, RFC, PCNA, Pol δ , and FEN1, Dna2, and DNA ligase where indicated for 4 min at 30 °C. The reactions were preincubated with RPA, PCNA, and RFC for 1 min at 30 °C, and then started by adding the other proteins in a mix (see "Experimental Procedures" for details). *C*, maturation of primers with a 10-nt (SKdc11) or 30-nt (SKdc12) 5'-flap. Assays were carried out as in *B*, for the indicated times. Analysis was on a 1% agarose gel with 0.5 μ g/ml ethidium bromide present.

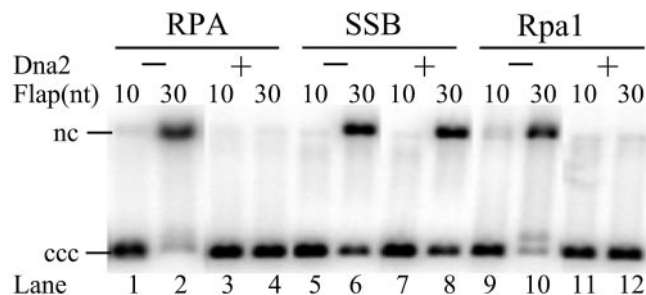

FIG. 5. Dna2 directed to the flap by the Rpa1 subunit of RPA. Assays containing 100 mM NaCl, RPA, RFC, PCNA, Pol δ , FEN1, DNA ligase, and Dna2 where indicated, were as described in Fig. 4C, with either SKdc11- (10-mer flap) or SKdc12 (30-mer flap)-primed DNA, and with either 1.15 μ g of RPA, 0.85 μ g of *E. coli* SSB, or 1 μ g of Rpa1 present as single stranded binding protein. Assays were for 4 min at 30 °C. Analysis was on a 1% agarose gel with 0.5 μ g/ml ethidium bromide present.

closed circles: $t[\text{ccc}]_{50} - t([\text{nc}] + [\text{ccc}])_{50}$. Under standard replication conditions with the concentration of DNA at 3.3 nM, PCNA at 13 nM, and Pol δ , FEN1, and DNA ligase at 5 nM, the maturation time was 22–25 s.

Several variables were altered to probe the response of this parameter to changing reaction conditions and enzyme levels. No difference was observed when the NaCl concentration was raised from 100 mM to 140 mM. Increasing the dNTP concentration from 100 μ M to 400 μ M each resulted in a higher rate of formation of nicked circles. However, the maturation time remained the same as covalently closed circles also accumulated more rapidly (data not shown). Increasing the levels of PCNA to 50 nM or reducing it to 5 nM, or increasing the level of Pol δ to 10 nM did not alter the kinetics of maturation (data not shown). An increase of the FEN1 concentration to 50 nM also did not affect the kinetics, however, decreasing the FEN1 concentration to 2 nM, a substoichiometrical level, provided some insights in the process. The rate of maturation of about half of the DNA molecules remained unaffected, but the rate of maturation of the remaining molecules was drastically reduced, and even after 4 min, 15–20% nicked circles remained (Fig. 6, *C* and *D*). These data strongly suggest that FEN1 forms an integral, stable component of the maturation complex and does not readily exchange among complexes.

Inclusion of Dna2 in the assay, either at 5 nM or 25 nM,

showed no effect when FEN1 was present at 5 nM; the kinetics of formation and decay of nicked circles and of the formation of covalently closed circles were not affected by Dna2 (data not shown). However, when FEN1 was present at the substoichiometrical level of 2 nM, addition of Dna2 did not affect the early stages of the reaction, but its presence prevented the accumulation of nicked circles in the later stages of the reaction (Fig. 6, *C* and *D*). Therefore, Dna2 appears to function in the rescue of maturation complexes only if FEN1 activity is impaired.

Like FEN1, DNA ligase is known to interact with PCNA, and efficient ligation requires that PCNA is properly loaded onto the substrate DNA (47, 48, 57). Therefore, we expected DNA ligase to function as a stable component of the maturation complex, as observed with FEN1. Surprisingly, however, the rate of maturation was substantially increased at higher concentrations of DNA ligase. At 50 nM DNA ligase, nicked circles accumulated to the extent of only 26% because they were more rapidly converted to covalently closed circles. The maturation time was reduced to 15–17 s at 50 nM DNA ligase (Fig. 6, *C* and *D*). A lower level of ligase, 15 nM, yielded an intermediate value of 17–19 s for the maturation time (data not shown). Therefore, it appears that DNA ligase remains only loosely associated with the complex, and increasing concentrations drives complex formation and increases maturation rates.

DNA Ligase Controls the Nick Translation Patch Length—Although it is obvious that during Okazaki-fragment maturation, nick translation has to proceed past the RNA-DNA junction, it is not known how far it proceeds prior to ligation or which factor(s) determine the patch length. Studies in the T4 DNA replication system, which is highly analogous to the eukaryotic systems, have indicated that ~30 nt of DNA are removed per Okazaki fragment during coupled leading- and lagging-strand DNA replication (58). We wanted to determine how much DNA was actually removed from a successfully replicated and ligated DNA molecule. To address this question, a set of RNA-DNA primers was used, each with 8 nt of RNA followed by either 6, 12, or 22 nt of DNA (Fig. 7A). A single radioactive label was incorporated with an exonuclease-deficient DNA polymerase and locked into place by a short pulse of DNA synthesis with a large excess of non-radioactive dNTPs, extending about 20–50 nt past the labeled position. This substrate was purified and used in the Okazaki-fragment maturation assay. Loss of label in the covalently closed product indicates that nick trans-

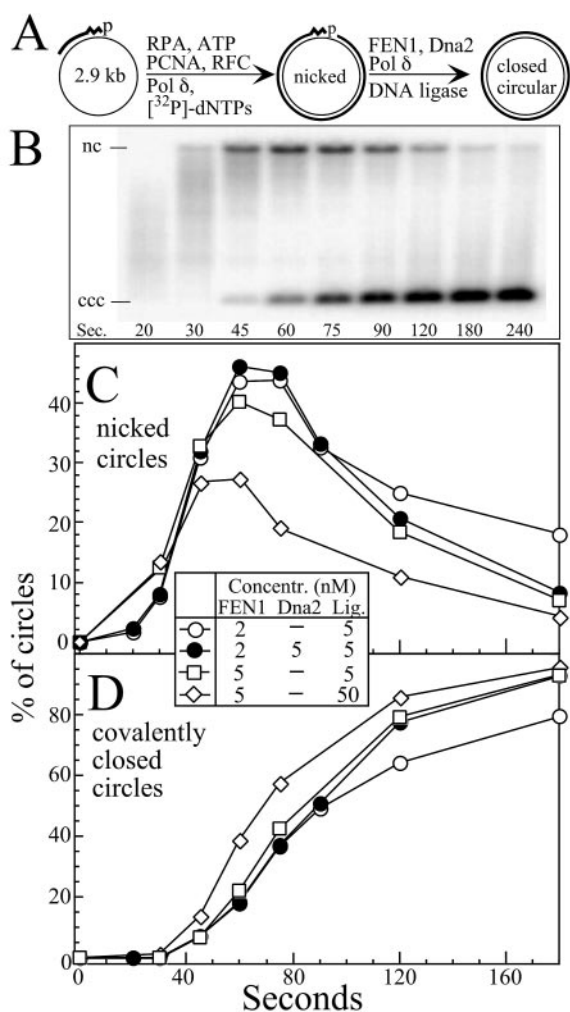

FIG. 6. Rates of Okazaki fragment maturation. *A*, schematic of the assay. The primer was SKrc14 with 8 nt of RNA followed by 22 nt of DNA. *B*, time course of maturation under standard conditions with 3.3 nM DNA, 5 nM Pol δ , 5 nM of FEN1, and 5 nM of DNA ligase. The reactions were preincubated with RPA, PCNA, and RFC for 1 min at 30 °C, and then started by adding the other proteins in a mix (see “Experimental Procedures” for details). Analysis was on a 1% agarose gel with 0.5 μ g/ml ethidium bromide present. *C*, accumulation and disappearance of nicked circles under the indicated experimental conditions. *D*, accumulation of covalently closed circles.

lation proceeded past the labeled position prior to ligation. Fig. 7*B* shows the results obtained when the label was inserted after the sixth nucleotide past the RNA-DNA junction, showing several controls and the effect of varying levels of FEN1, Dna2, and DNA ligase on the percent retention of label in the covalently closed DNA. The same assays were carried out with primers in which the label was introduced at positions 12 or 22 after the RNA-DNA junction (data not shown). For each experiment, the percent retention of label was plotted as a function of the position of the label in nucleotides past the RNA/DNA junction, and the level of 50% retention of label was determined by interpolation or extrapolation to obtain the average nick translation patch length (Fig. 7*C*).

This type of analysis indicates that under our standard replication and maturation conditions, the average nick translation patch is 8–12 nt (the range of three independent experiments) past the RNA-DNA junction, with or without Dna2 present. However, in the presence of 50 nM of DNA ligase, the patch size is reduced to only 4–6 nt. A lower concentration of DNA ligase (15 nM) was almost as effective (Fig. 7*B*, lane 5).

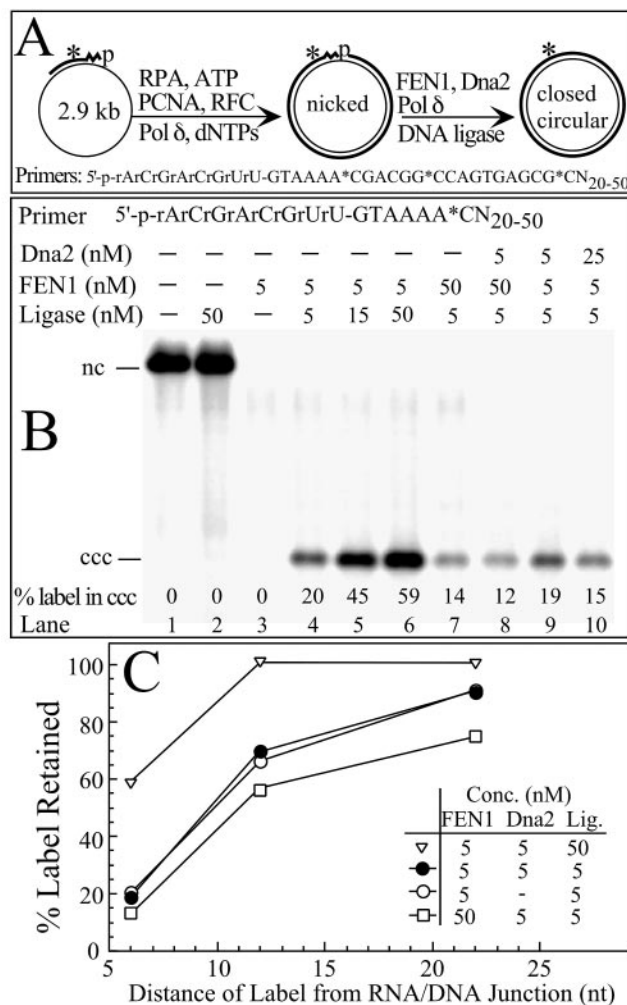

FIG. 7. Nick translation patch length during maturation. *A*, schematic of the assay. The starred position indicates the position of the label in each of three individual primers. *B*, assays containing 100 mM NaCl, RPA, RFC, PCNA, Pol δ , and FEN1, DNA ligase, or Dna2 as indicated, were carried out with SKII ssDNA primed with 3'-end labeled SKrc14–14 (5'-p-rArCrGrArCrGrUrU-GTAAAA*CN₂₀₋₅₀; see “Experimental Procedures”). The reactions were preincubated with RPA, PCNA, and RFC for 1 min at 30 °C and then started by adding the other proteins in a mix. Incubation was for 4 min at 30 °C and analysis was on a 1% agarose gel with 0.5 μ g/ml ethidium bromide present. *C*, quantitation of label remaining for assays similar to described in *B* but carried out with either 3'-end labeled SKrc14–14, SKrc14–20 (5'-p-rArCrGrArCrGrUrU-GTAAAAACGACGG*CN₂₀₋₅₀), or SKrc14–30 (5'-p-rArCrGrArCrGrUrU-GTAAAAACGACGGCCAGTGAGCG*CN₂₀₋₅₀) as primer.

Very high levels of FEN1 (50 nM) slightly increased the patch size to 10–15 nt from 8–12nt.

DISCUSSION

Our kinetic analysis of gap filling and Okazaki-fragment synthesis has yielded a picture of a remarkably efficient interaction between Pol δ and FEN1. PCNA is the organizing force in this coupling between synthesis and degradation, as exemplified by the observation that a FEN1 mutant that is only deficient for interaction with PCNA, is unable to carry out nick translation with Pol δ (Fig. 2). All of our studies were carried out at 100–140 mM NaCl, which lends specificity to the reactions by inhibiting binding of the enzymes to the DNA when PCNA is not loaded (Figs. 1 and 2).

When Pol δ encounters downstream double-stranded DNA, it pauses at the position of a precise nick with high frequency as follows from the observation that in the presence of DNA li-

gase, 87% ligation occurred (Fig. 4B, lane 1). Without ligase present, pause sites distributed evenly over the position of the precise nick and the +1 position (Fig. 1B). Not all replication complexes go into a strand-displacement synthesis, which may be due to complex dissociation upon encountering the double-stranded junction, which at least in the T4 system is a fast process (59). Because of the thermolabile nature of RFC, re-loading of PCNA and complex reassembly is not expected to be very efficient in our assay system, which may explain why some DNA molecules never underwent strand-displacement synthesis (60).

Although gap filling by Pol δ coupled to ligation is a fairly efficient process, it is by no means perfect, and certainly inside the cell a ligation failure rate of 13% would be unacceptable (Fig. 4, lane 1). Addition of FEN1 to the assay initiated nick translation and produced essentially fully ligated products. For the maturation of RNA-ended junctions and flap junctions, the generation of ligatable nicks became entirely dependent on nick translation, but proceeded also very efficiently as long as flaps were small. The balanced exchange of the nick between the 5' \rightarrow 3'-polymerase domain of Pol δ and the 5' \rightarrow 3'-exonuclease activity of FEN1 resembles that of prokaryotic DNA polymerase I in which both activities are combined in the same polypeptide (61). Remarkably, the rate of strand displacement synthesis by Pol δ (1.5 nt/sec) is comparable with the rate of nick translation (1.7 nt/sec) when measured over long stretches of DNA (Fig. 3). Therefore, it appears that the observed large stimulation with which the polymerase proceeds through a downstream primer in the presence of FEN1 may be due to more rapid initiation, *i.e.* departure from the paused state, rather than elongation of strand displacement or nick translation, respectively (Fig. 2).

Depending on the DNA ligase concentration, the nick-translation patch during Okazaki-fragment maturation was 4–12 nt in length (past the RNA/DNA junction). Our results cannot be easily compared with a recent T4 maturation study, because the patch of \sim 30 nt in that study was a weighted-average number calculated from all replication products, whereas we uniquely measured the patch in successfully ligated replication products (58). In our model system, the patch length is an important determinant for the rate with which Okazaki fragments are matured (see below).

Dna2 Requirement in Okazaki Fragment Maturation—In our model studies of Okazaki fragment maturation we used an RNA-primed circular template on which the replication complex encounters the RNA primer after complete replication around the circle (Fig. 6A). In this system, we found no requirement for the Dna2 nuclease/helicase as long as all relevant enzymes were present in slight excess over DNA. Neither the efficiency of ligation (Fig. 4B), the rate of maturation (Fig. 6) nor the size of the nick-translation patch (Fig. 7) were affected by the presence of Dna2.

However, Dna2 became a stimulatory component of the maturation complex when the concentration of FEN1 was less than stoichiometric (Fig. 6D). The data are consistent with a model in which those replication complexes that contained FEN1 matured normally, whereas the remaining complexes showed a strong delay in maturation. The latter deficiency was rescued by addition of Dna2. Presumably, those complexes lacking FEN1 proceeded to carry out excessive strand-displacement synthesis to the extent that even FEN1 recycled from completely ligated products was unable to act on those DNA substrates. These inert substrates probably resemble our model 30-mer flap substrate, which is inactive for nick translation with FEN1 because of RPA binding to the flap. Dna2 would then be able to bind to the flap and partially degrade it because

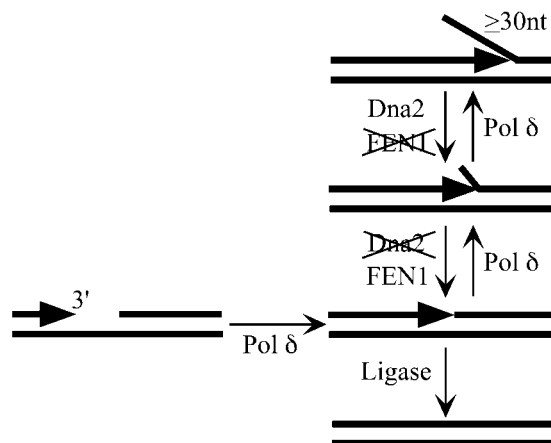

FIG. 8. Model of the actions of Pol δ , FEN1, and Dna2 during gap filling synthesis. The model assumes that RPA binds to long flaps only. See text for details.

of its interaction with RPA. The large subunit, Rpa1, suffices, because Rpa1, but not *E. coli* SSB, allowed rescue of maturation of long flaps by Dna2.

Interestingly, although Dna2 alone supported Okazaki-fragment maturation much more poorly than FEN1, a substantial percent of ligated products was still observed, particularly with the flap substrates (Fig. 4, B and C). Studies of the cutting specificity of Dna2 on 5'-flap substrates have shown that it leaves a 5- to 10-nt 5'-flap (36). When in the same study the specificity of cutting by Dna2 was measured in an assay system in which replication by Pol δ encountered a downstream RNA/DNA primer (comparable with the system shown in Fig. 4A), cutting by Dna2 of that RNA/DNA primer was observed mainly at sites 2–4 nt beyond the RNA/DNA junction. Because this activity depended on DNA replication, it was proposed that strand-displacement synthesis generated the flap to be cut by Dna2. What could not be measured in this coupled replication-degradation assay was whether the Dna2-mediated cut occurred in the duplex region ahead of the displaced strand, or at the precise nick position, or, most likely, into the ss region exposed by strand displacement synthesis by Pol δ . If the cutting specificity of Dna2 remained the same regardless whether the DNA was a pre-formed ss flap or a flap generated by strand-displacement synthesis, cutting would be in the ss region only and leave a 5- to 10-nt 5'-flap (36). In order for this 5'-flapped molecule to be matured into a ligatable nick in the absence of FEN1 and barring additional degradation by Dna2, one would have to assume that the 3' \rightarrow 5'-exonuclease activity of Pol δ would have the ability to degrade back the strand it had synthesized to allow the displaced strand to rehybridize to the template to produce a proper nick for ligation. Therefore, assuming that the Dna2 cleavage specificity is similar under our reaction conditions (100 mM NaCl, 30 $^{\circ}$ C) and those used by Bae and Seo (no salt, 37 $^{\circ}$ C; ref. 36), it is likely that the exonuclease activity of Pol δ is important in producing a ligatable nick in the absence of FEN1. In the companion paper, this issue will be addressed in an assay system in which the 3' \rightarrow 5'-exonuclease of Pol δ has been inactivated (52).

The sharp demarcation we notice in the maturation of a 10-mer flap versus a 30-mer flap is because RPA requires a 30-mer oligonucleotide for binding (62). However, it is conceivable that *in vivo* the maturation of even small flaps requires Dna2 activity because other proteins in the replisome may bind to small flaps and inhibit the activity of FEN1. Furthermore, as our *in vitro* studies cannot address how often *in vivo* maturation with FEN1 alone is unsuccessful, and, second, how many unmatured Okazaki fragments would have to be accumulated to cause lethality

to the cell, we cannot address whether the essential nature of DNA2 is due to its constitutively required presence at each Okazaki fragment, or to the rescue of a small number of stalled Okazaki fragments which otherwise would be lethal. However, our *in vitro* results do suggest the latter as a reasonable scenario (Fig. 8). Our data are not in disagreement with a recent study by Bae *et al.* (34). Because in that study all maturation experiments with DNA ligase were performed on substrates with long 5'-flaps, an absolute requirement for Dna2 was measured, as we did with our 30-mer flap substrate.

DNA Ligase Is Loosely Associated with the Maturation Complex—The biphasic response resulting from the maturation studies with substoichiometrical concentrations of FEN suggest that FEN1 forms a stable integral component of the maturation complex. The same is not the case for DNA ligase. Even though DNA ligase has a PCNA-binding domain similar to FEN1, and the interaction between PCNA and DNA ligase I is critical for joining Okazaki fragments and for long-patch base-excision repair in mammalian cells, we observed a titratable response which saturated at an ~15-fold molar excess of DNA ligase (47). Perhaps, on the DNA, the interaction between PCNA and DNA ligase is less strong, or alternatively, FEN1 and/or Pol δ compete with DNA ligase for the same binding site(s) on PCNA. Presumably, other factor(s) may be required *in vivo* to keep DNA ligase positioned in the maturation complex.

Efficiency of Okazaki Fragment Maturation—Although Okazaki-fragment maturation in our *in vitro* system is very efficient, at least as measured by end-product formation, the rates of maturation may still be incompatible with cellular metabolism. Assuming that the average length of an Okazaki fragment is ~150 nt, it would take 3–4 s for elongation to be complete at a fork rate of 50 nt/sec (55). No information is available regarding the rate of initiation, *i.e.* priming by DNA polymerase α -primase. However, maturation under our most favorable conditions, with high concentrations of DNA ligase, still takes an average of 15–17 s. Most of this period is taken up by nick translation through an RNA-DNA stretch of ~15 nt at ~1.7 nt/s. Under these conditions, one would expect Okazaki fragments to accumulate inside the cell, which appears not to be the case (63). Therefore, to improve maturation rates one would either need to improve the rate of nick translation or bypass extensive nick translation through helicase action to rapidly displace the RNA-DNA section to be matured. Dna2, which has helicase activity, did not accelerate maturation (Fig. 6) (4, 36). Furthermore, the essential activity of Dna2 is the nuclease, rather than the helicase (9). Therefore, another DNA helicase may be involved in this process.

Acknowledgments—We thank Kim Gerik and Carrie Welch for technical assistance and John Majors for critical discussions during the course of this work.

REFERENCES

- Bambara, R. A., Murante, R. S., and Henriksen, L. A. (1997) *J. Biol. Chem.* **272**, 4647–4650
- MacNeill, S. A., and Burgers, P. M. (2000) in *The Yeast Nucleus: Frontiers in Molecular Biology* (Fantes, P., and Beggs, J., eds), pp. 19–57, Oxford University Press, Oxford
- Chen, J. Z., Qiu, J., Shen, B., and Holmquist, G. P. (2000) *Nucleic Acids Res.* **28**, 3649–3656
- Budd, M. E., Choe, W.-C., and Campbell, J. (1995) *J. Biol. Chem.* **270**, 26766–26769
- Budd, M. E., and Campbell, J. L. (1997) *Mol. Cell. Biol.* **17**, 2136–2142
- Formosa, T., and Nittis, T. (1999) *Genetics* **151**, 1459–1470
- Kang, H. Y., Choi, E., Bae, S. H., Lee, K. H., Gim, B. S., Kim, H. D., Park, C., MacNeill, S. A., and Seo, Y. S. (2000) *Genetics* **155**, 1055–1067
- Bae, S. H., Choi, E., Lee, K. H., Park, J. S., Lee, S. H., and Seo, Y. S. (1998) *J. Biol. Chem.* **273**, 26880–26890
- Lee, K. H., Kim, D. W., Bae, S. H., Kim, J. A., Ryu, G. H., Kwon, Y. N., Kim, K. A., Koo, H. S., and Seo, Y. S. (2000) *Nucleic Acids Res.* **28**, 2873–2881
- Budd, M. E., Choe, W., and Campbell, J. L. (2000) *J. Biol. Chem.* **275**, 16518–16529
- Parenteau, J., and Wellinger, R. J. (1999) *Mol. Cell. Biol.* **19**, 4143–4152
- Choe, W., Budd, M., Imamura, O., Hoopes, L., and Campbell, J. L. (2002) *Mol. Cell. Biol.* **22**, 4202–4217
- Klungland, A., and Lindahl, T. (1997) *EMBO J.* **16**, 3341–3348
- Kim, K., Biade, S., and Matsumoto, Y. (1998) *J. Biol. Chem.* **273**, 8842–8848
- Matsumoto, Y. (2001) *Progr. Nucleic Acids Res. Mol. Biol.* **68**, 129–138
- Johnson, R. E., Kovvali, G. K., Prakash, L., and Prakash, S. (1995) *Science* **269**, 238–240
- Tishkoff, D. X., Filosi, N., Gaida, G. M., and Kolodner, R. D. (1997) *Cell* **88**, 253–263
- Kokoska, R. J., Stefanovic, L., Tran, H. T., Resnick, M. A., Gordenin, D. A., and Petes, T. D. (1998) *Mol. Cell. Biol.* **18**, 2779–2788
- Negritto, M. C., Qiu, J., Ratay, D. O., Shen, B., and Bailis, A. M. (2001) *Mol. Cell. Biol.* **21**, 2349–2358
- Xie, Y., Liu, Y., Argueso, J. L., Henriksen, L. A., Kao, H. I., Bambara, R. A., and Alani, E. (2001) *Mol. Cell. Biol.* **21**, 4889–4899
- Henriksen, L. A., Veeraraghavan, J., Chafin, D. R., and Bambara, R. A. (2002) *J. Biol. Chem.* **277**, 22361–22369
- Johnson, R. E., Kovvali, G. K., Prakash, L., and Prakash, S. (1998) *Curr. Genet.* **34**, 21–29
- Symington, L. S. (1998) *Nucleic Acids Res.* **26**, 5589–5595
- Tishkoff, D. X., Boerger, A. L., Bertrand, P., Filosi, N., Gaida, G. M., Kane, M. F., and Kolodner, R. D. (1997) *Proc. Natl. Acad. Sci. U. S. A.* **94**, 7487–7492
- Li, X., Li, J., Harrington, J., Lieber, M. R., and Burgers, P. M. (1995) *J. Biol. Chem.* **270**, 22109–22112
- Eissenberg, J. C., Ayyagari, R., Gomes, X. V., and Burgers, P. (1997) *Mol. Cell. Biol.* **17**, 6367–6378
- Kao, H. I., Henriksen, L. A., Liu, Y., and Bambara, R. A. (2002) *J. Biol. Chem.* **277**, 14379–14389
- Hosfield, D. J., Mol, C. D., Shen, B., and Tainer, J. A. (1998) *Cell* **95**, 135–146
- Hwang, K. Y., Baek, K., Kim, H. Y., and Cho, Y. (1998) *Nat. Struct. Biol.* **5**, 707–713
- Murante, R. S., Rust, L., and Bambara, R. A. (1995) *J. Biol. Chem.* **270**, 30377–30383
- Xu, Y., Potapova, O., Leschziner, A. E., Grindley, N. D., and Joyce, C. M. (2001) *J. Biol. Chem.* **276**, 30167–30177
- Rigby, P. W., Dieckmann, M., Rhodes, C., and Berg, P. (1977) *J. Mol. Biol.* **113**, 237–251
- Turchi, J. J., and Bambara, R. A. (1993) *J. Biol. Chem.* **268**, 15136–15141
- Bae, S. H., Bae, K. H., Kim, J. A., and Seo, Y. S. (2001) *Nature* **412**, 456–461
- Maga, G., Villani, G., Tillement, V., Stucki, M., Locatelli, G. A., Frouin, I., Spadari, S., and Hubscher, U. (2001) *Proc. Natl. Acad. Sci. U. S. A.* **98**, 14298–14303
- Bae, S. H., and Seo, Y. S. (2000) *J. Biol. Chem.* **275**, 38022–38031
- Waga, S., Bauer, G., and Stillman, B. (1994) *J. Biol. Chem.* **269**, 10923–10934
- Burgers, P. M., and Gerik, K. J. (1998) *J. Biol. Chem.* **273**, 19756–19762
- Burgers, P. M. (1999) *Methods* **18**, 349–355
- Henriksen, L. A., Umbricht, C. B., and Wold, M. S. (1994) *J. Biol. Chem.* **269**, 11121–11132
- Gomes, X. V., Gary, S. L., and Burgers, P. M. (2000) *J. Biol. Chem.* **275**, 14541–14549
- Gomes, X. V., and Burgers, P. M. J. (2000) *EMBO J.* **19**, 3811–3821
- Sambrook, J., Fritsch, E. F., and Maniatis, T. (1989) *Molecular Cloning: A Laboratory Manual*, Cold Spring Harbor Laboratory, Cold Spring Harbor, NY
- Yamamoto, K. R., Alberts, B. M., Benzinger, R., Lawhorne, L., and Treiber, G. (1970) *Virology* **40**, 734–744
- Montecucco, A., Rossi, R., Levin, D. S., Gary, R., Park, M. S., Motycka, T. A., Ciarrocchi, G., Villa, A., Biamonti, G., and Tomkinson, A. E. (1998) *EMBO J.* **17**, 3786–3795
- Mossi, R., Ferrari, E., and Hubscher, U. (1998) *J. Biol. Chem.* **273**, 14322–14330
- Levin, D. S., McKenna, A. E., Motycka, T. A., Matsumoto, Y., and Tomkinson, A. E. (2000) *Curr. Biol.* **10**, 919–922
- Tom, S., Henriksen, L. A., Park, M. S., and Bambara, R. A. (2001) *J. Biol. Chem.* **276**, 24817–24825
- Burgers, P. M. J., and Yoder, B. L. (1993) *J. Biol. Chem.* **268**, 19923–19936
- Podust, L. M., Podust, V. N., Floth, C., and Hubscher, U. (1994) *Nucleic Acids Res.* **22**, 2970–2975
- Kaboord, B. F., and Benkovic, S. J. (1993) *Proc. Natl. Acad. Sci. U. S. A.* **90**, 10881–10885
- Jin, Y. H., Ayyagari, R., Resnick, M. A., Gordenin, D. A., and Burgers, P. M. (2003) *J. Biol. Chem.* **278**, 1626–1633
- Warbrick, E. (1998) *Bioessays* **20**, 195–199
- Gary, R., Park, M. S., Nolan, J. P., Cornelius, H. L., Kozyreva, O. G., Tran, H. T., Lobachev, K. S., Resnick, M. A., and Gordenin, D. A. (1999) *Mol. Cell. Biol.* **19**, 5373–5382
- Raguraman, M. K., Winzler, E. A., Collingwood, D., Hunt, S., Wodicka, L., Conway, A., Lockhart, D. J., Davis, R. W., Brewer, B. J., and Fangman, W. L. (2001) *Science* **294**, 115–121
- Tomkinson, A. E., Tappe, N. J., and Friedberg, E. C. (1992) *Biochemistry* **31**, 11762–11771
- Matsumoto, Y., Kim, K., Hurwitz, J., Gary, R., Levin, D. S., Tomkinson, A. E., and Park, M. S. (1999) *J. Biol. Chem.* **274**, 33703–33708
- Bhagwat, M., and Nossal, N. G. (2001) *J. Biol. Chem.* **276**, 28516–28524
- Hacker, K. J., and Alberts, B. M. (1994) *J. Biol. Chem.* **269**, 24221–24228
- Yoder, B. L., and Burgers, P. M. J. (1991) *J. Biol. Chem.* **266**, 22689–22697
- Ma, W. P., Kaiser, M. W., Lyamicheva, N., Schaefer, J. J., Allawi, H. T., Takova, T., Neri, B. P., and Lyamichev, V. I. (2000) *J. Biol. Chem.* **275**, 24693–24700
- Kim, C., Snyder, R. O., and Wold, M. S. (1992) *Mol. Cell. Biol.* **12**, 3050–3059
- Bielinsky, A. K., and Gerbi, S. A. (1999) *Mol. Cell* **3**, 477–486